

Identification of a Career Path for DHS Contact Representatives

Thomas J. Lyons

Theodore L. Hayes

J. Anthony Bayless

U.S. Department of Homeland Security

Presented as part of the symposium:

Maximizing the Effectiveness of DHS Contact Representatives (D.M. Pollack, Chair)

27th Annual IPMAAC Conference on Personnel Assessment

June 2003, Baltimore, MD

Goals of the Legacy INS Career Path Initiative

- **Identify career path occupations**
- **Identify duties, competencies, and training needs for each target occupation**
- **Determine career ladders across occupations**
- **Develop career self-management options**

Project Process

- **Clarify combinations of job titles and pay grade levels**
- **Review/Develop list of duties & rate importance**
- **Review/Rate general competencies**
- **Review/Develop technical competencies**
- **Review training requirements**
- **Develop career path flow chart**

Job Titles / Pay Grades

Pay Grade(s)	Job Title	Job Level
5/6	Contact Representative	Entry-level
7	Contact Representative	Journeyman-level
8	Lead Contact Representative	Journeyman-level +
9	Supervisory Contact Representative	1 st line supervisor
10/11	Information Services Manager	Managerial level

General Competencies - Contact Representatives

Thinking Skills

Arithmetic/Mathematical Reasoning (7 - 11)
Creative Thinking (7 - 11)
Decision-Making (5 - 11)
Judgment (5 - 11)
Learning (7 - 11)
Mental Visualization (8 - 11)
Memory (7 - 11)
Perceptual Speed (8 - 11)
Problem Solving (5 - 11)
Reading (5 - 11)
Reasoning (7 - 11)

Personal Characteristics

Conscientiousness (5 - 11)
Cooperativeness/Sensitivity to the Needs of Others (7 - 11)
Emotional Maturity (7 - 11)
Flexibility (9 - 11)
Integrity/Honesty (5 - 11)
Self-Presentation (5 - 11)

Physical & Motor Skills

(none)

Interacting with Others

Leadership (8 - 11)
Negotiating (8 - 11)
Oral Communication (5 - 11)
Teaching Others (7 - 11)
Teamwork (7 - 11)
Writing (7 - 11)

Work Management Skills

Managing Human Resources (9 - 11)
Managing Resources (10/11)
Managing/Organizing Information (7 - 11)
Org./Community Awareness (7 - 11)
Planning & Evaluating (8 - 11)
Self-Management (8 - 11)
Technology Application (5 - 11)
Vision (7 - 11)

Technical Competencies - Contact Representatives

All Contact Representatives

Knowledge of the INA & immigration law
Computer databases
Skill in providing customer service
Knowledge of laws, regulations, precedents,
and policies for adjudications
Knowledge of visa issuance procedures
Knowledge of District & Service Center
operations
Knowledge of office operations

Leads/Supervisors Only

Knowledge of IIO operations
Ability to detect fraud
Knowledge of security
Ability to research technical information
Knowledge of intelligence
Knowledge of administration
Ability to identify/meet training
Ability to evaluate performance
Knowledge of staffing
Ability to discipline employees
Knowledge of EAP, LMR, EEO,
budgeting, ethics

Mandatory Training for Contact Representatives

(beyond other required agency-related training)

- Immigration Information Officer training
- EEO
- Computer security
- Ethics (supervisors take an additional course)
- Computer usage skills
- Telephony instrument training
- Telephony “soft skills”
- Quality assurance monitoring training
- Stress management

Career Development

How can I achieve mastery of a critical competency?

Competency:

*Knowledge of the
Immigration &
Nationality Act*

Resource:



<http://www4.law.cornell.edu/uscode/8/ch12.html>

Practice note: It is difficult and sometimes impossible to gain certification in certain competencies, especially in a one-time-only training experience.

Career Path for Contact Representative

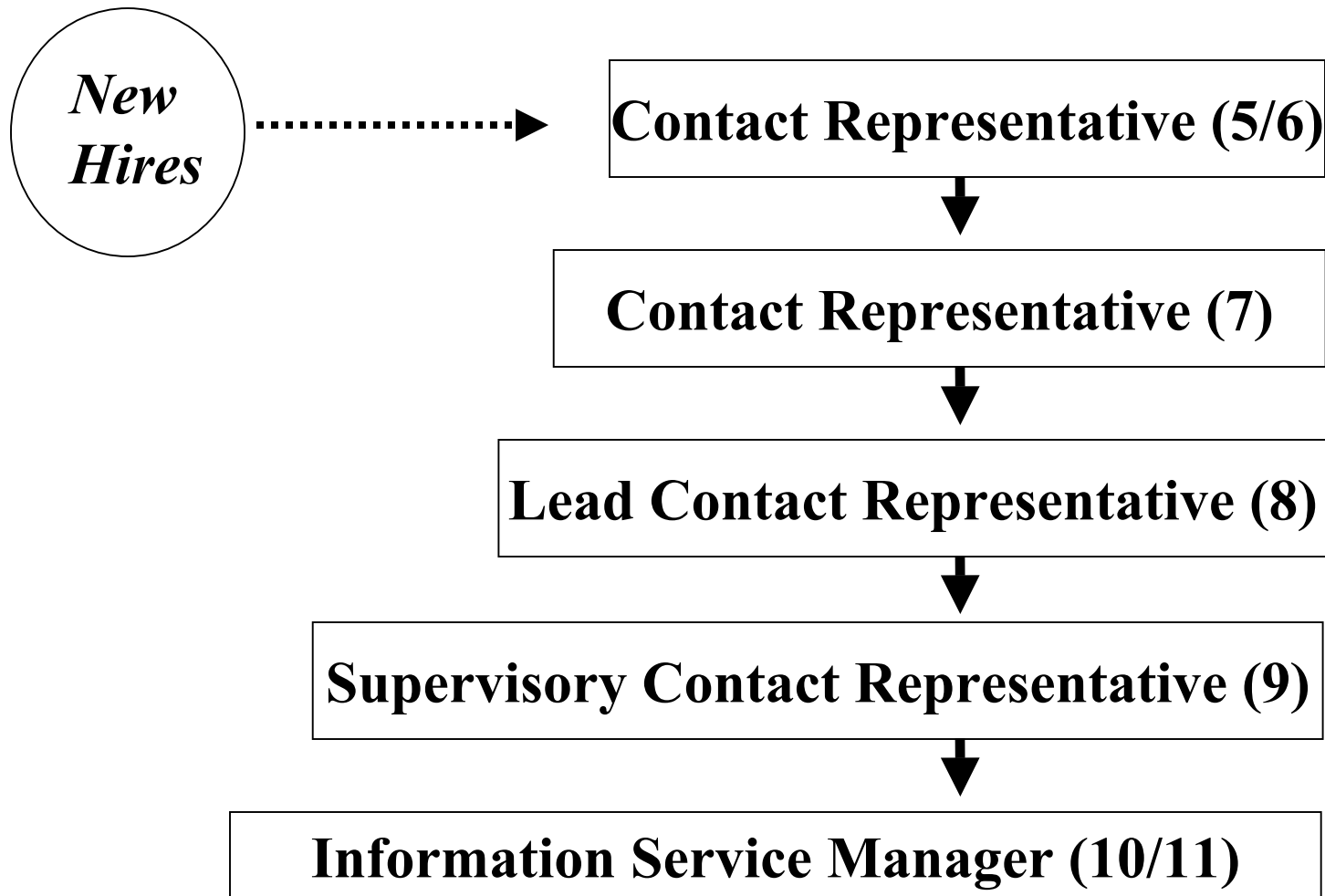

Bureau of Citizenship & Immigration Services

Officer Corps Positions Career Transition Points

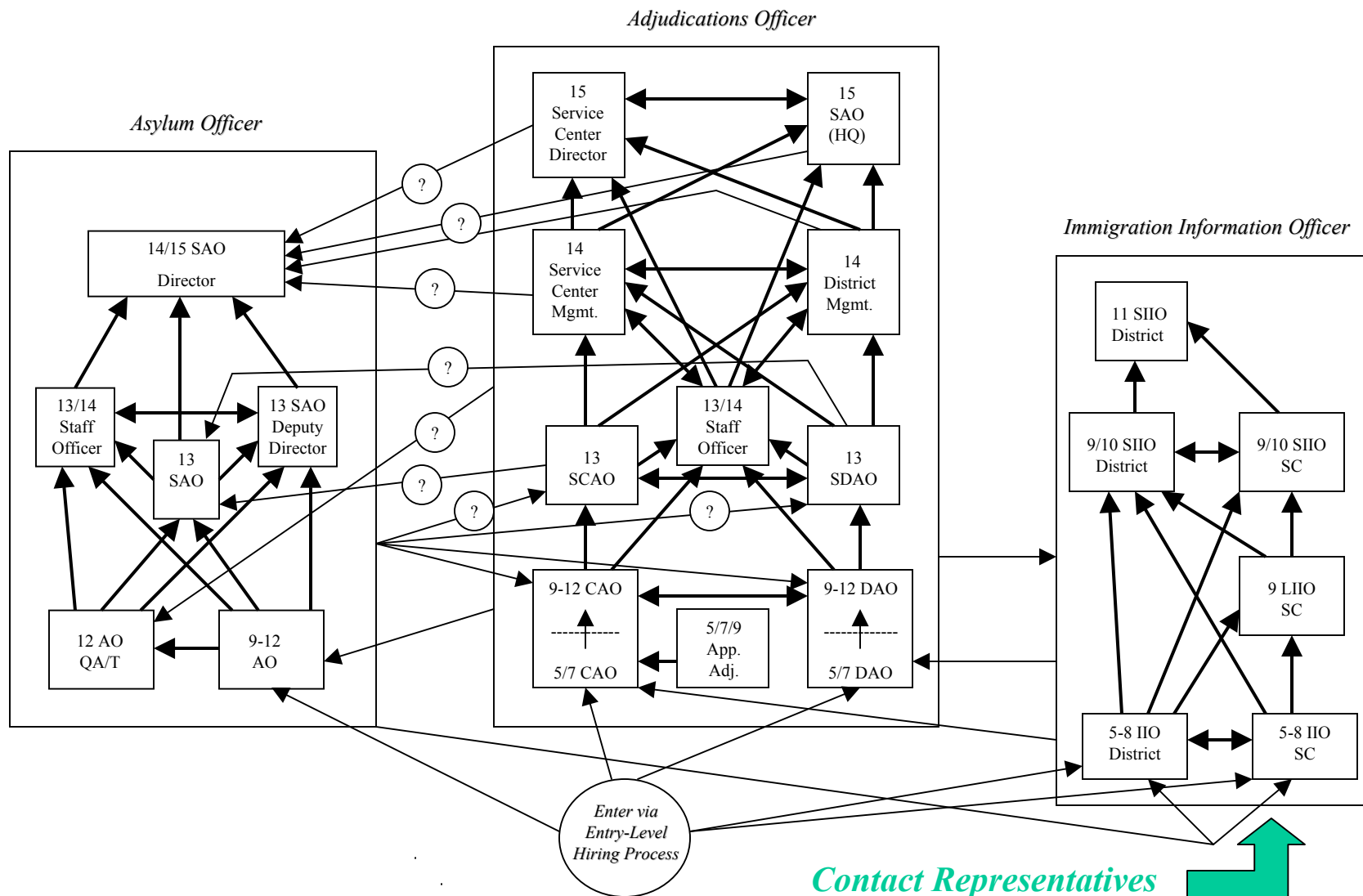

Contact Representatives
can apply this way